

BALL VALVES

BV-TP-FB-Series-Screwed

General Features

- Full Bore Ball
- Three piece Body design with NPT(f)/BSP(f) Screwed ends / Socket welded to ASME B16.11
- Rated to 150/300 class, higher ratings on request
- Actuator mounting is designed to ISO 5211:2017
- Solid Stainless steel Ball with mirror finish is standard
- This ensures leak tight sealing and low torque operation
- Stem with shoulder provides for blowout proof and hence more the pressure better the sealing to atmosphere
- Thrust seals and stem packing seals are used to seal leakage to atmosphere
- Handlever actuator is Standard
- Electric and Pneumatic actuators can be supplied on request
- Pressure testing as per API 598

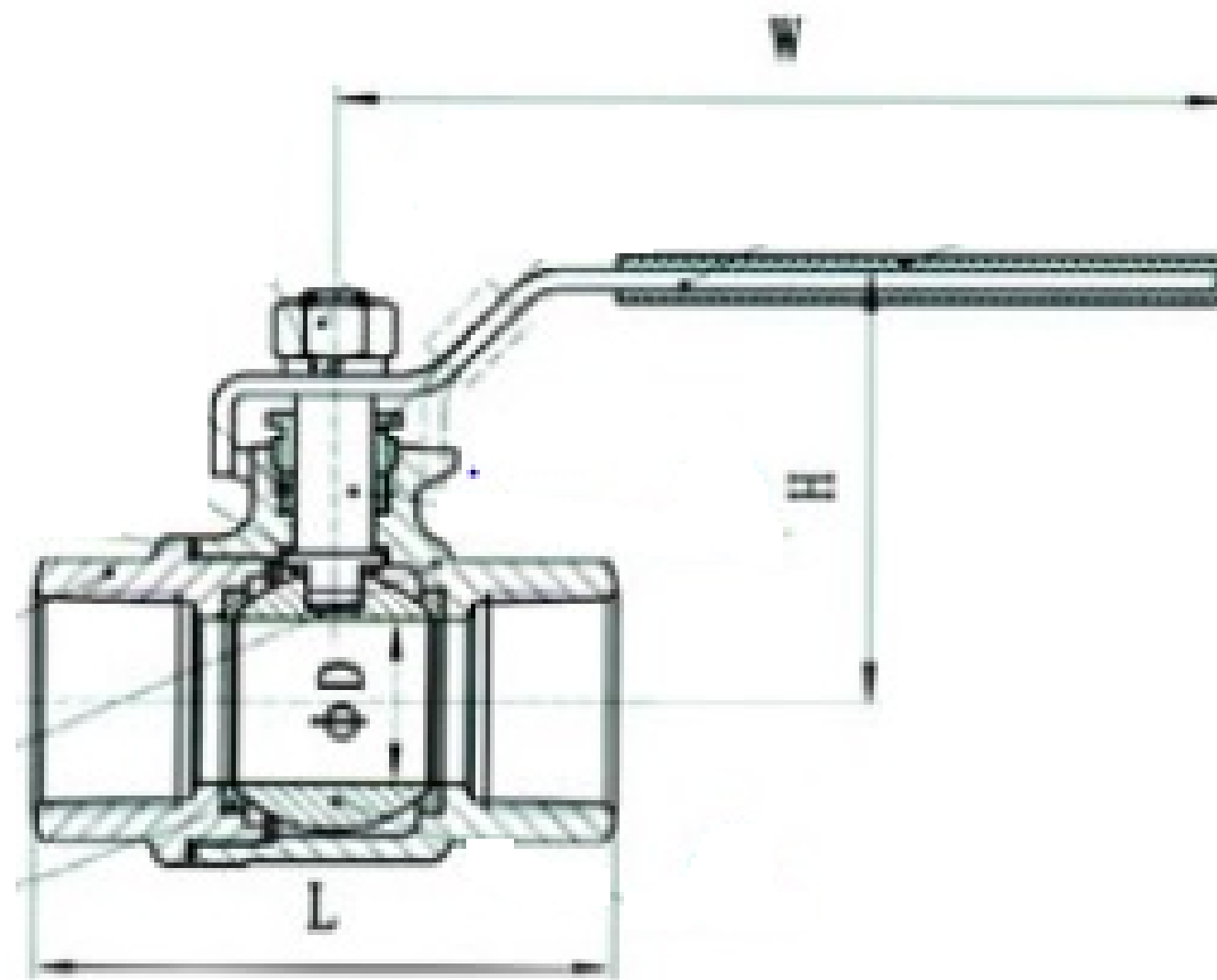

Material Specification

| COMPONENT | MATERIAL |
|-----------|--|
| Body | ASTM A216 WCB, A105, CF8, CF8M, Barstock CS, CF3, CF3M |
| Ball | SS 316, SS 304, SS 304 L, SS 316 L |
| Shaft | SS 316, SS 304, SS 304 L, SS 316 L |
| Seat | PTFE, Carbon filled PTFE on request |
| Seal | PTFE, Graphite |

Dimensions

| SIZE | H | W | L |
|---------------|----|-----|-----|
| NB | mm | mm | mm |
| 15 NB (1/2") | 52 | 103 | 58 |
| 20 NB (3/4") | 61 | 123 | 65 |
| 25 NB (1") | 65 | 123 | 77 |
| 32 NB (1.25") | 79 | 153 | 90 |
| 40 NB (1.5") | 83 | 153 | 98 |
| 50 NB (2") | 97 | 185 | 121 |

Cv Values

| SIZE (NB) | 15 | 20 | 25 | 32 | 40 | 50 | 65 | 80 | 100 | 150 | 200 |
|-----------|----|----|-----|-----|-----|-----|-----|------|------|------|------|
| Cv | 20 | 50 | 100 | 135 | 225 | 465 | 770 | 1090 | 1970 | 4635 | 8565 |
| Kv | 17 | 45 | 85 | 115 | 220 | 395 | 655 | 930 | 1675 | 3940 | 7280 |

